



# Extra Class National Championship 2011

Will be sailed at  
Port Owen Yacht Club

From

Friday, 14<sup>th</sup> October 2011 to Sunday, 16<sup>th</sup> October 2011

Sanctioned 22 June 2011

## NOTICE OF RACE

### 1. RULES

1.1 The regatta will be governed by the rules as defined in the Racing Rules of Sailing (RRS) 2009-12.

1.2 The following prescriptions of South African Sailing (SAS) will apply: **"The SA Sailing Requirements for National Championships"**.

1.3 Boats participating in this regatta shall conform to the Equipment Rules of Sailing (ERS) 2009-12, the Class Rules of the Extra Class, this Notice of Race, and the Sailing Instructions.

### 2. ADVERTISING

Advertising is permitted in terms of ISAF Regulation 20.

Boats may be required to display event advertising on the forward part of the hull.

### 3. ELIGIBILITY AND ENTRY

3.1 In accordance with the International Sailing Federation (ISAF) Regulation 19 (Eligibility Code), all competitors (Helmspersons and all other crew) shall be members in good standing of a Yacht Club affiliated to and in good standing with SAS or their Member National Authority in the case of non-South Africans. The Yacht Club name and membership details shall be stated on the entry form or crew list. Current valid SAS Membership Cards or similar proof of MNA Membership in cases of non-South Africans shall be presented at Registration.

3.2 The regatta is open to all boats of the Extra class.

3.3 Eligible boats may enter by completing the attached form and sending it to: [ian@gybeset.co.za](mailto:ian@gybeset.co.za) by 12 October 2011. The required fee is payable at Registration or by EFT, directly into the Class Bank Account.

### 4. FEES

4.1 Required fees are as follows:

Class Fee: R70 (if not a paid up Member).

Entry Fee: R200.

4.1 Late entry fees are as follows:

Class Fee: R70 (if not a paid up Member).

Late Entry Fee: R250.

#### 4.2 Other Fees:

All Entry Fees and Class subscriptions shall be paid prior to the close of Registration. Failure to meet this requirement will result in the affected yacht being recorded as Did Not Compete until such time as the required payment/s are made. This changes rule A11 (DNC).

### 5. SCHEDULE

5.1 Registration: Friday 14 October 2011 from 10h00 to 13h00.

5.3 Dates of racing:

14 October 2011 ~ Racing

15 October 2011 ~ Racing

16 October 2011 ~ Racing

5.4 Maximum Number of races: 16

5.5 The scheduled time of the warning signal for the first race on Friday, 14 October 2011, is 13h30. The scheduled time for the warning signal for the first race of each subsequent day will be displayed on the regatta notice board.

### 6. MEASUREMENTS

Spot measurements may be taken at any stage during the regatta.

### 7. SAILING INSTRUCTIONS

Sailing Instructions will be available from the Regatta Secretary on completion of registration formalities.

### 8. VENUE

Racing will take place in St. Helena Bay, outside the Berg River mouth or on the Berg River.

### 9. THE COURSES

The diagrams in Addendum #1 show the general courses, including the approximate angles between legs, the order in which marks are to be passed, and the side on which each mark is to be left.

### 10. SCORING

10.1 Low Point System of Appendix A4.1 will apply.

10.2 Four races are required to be completed to constitute a series.

10.3 (a) When fewer than 5 races have been completed, a boat's series score will be the total of her race scores.

(b) When from 5 to 9 races have been completed, a boat's series score will be the total of her race scores excluding her worst score.

(c) When 10 or more races have been completed, a boat's series score will be the total of her races excluding her two worst scores.

## **11. NATIONAL CHAMPIONSHIP REQUIREMENTS**

In order to qualify as a National Class Championship the following criteria shall be satisfied:

- A minimum of ten valid entries have been received no later than the closing time for entries one hour before the scheduled starting time of the first race
- At least ten finishers in any two races of the series.
- At least four races completed.

## **12. SAFETY**

12.1 Yachts shall comply with their class buoyancy and safety requirements.

12.2 All competitors shall wear a personal buoyancy aid capable of supporting a 5 kg steel weight at all times while afloat in a yacht.

12.4 Wet or dry suits do not constitute adequate buoyancy!

## **13. SUPPORT BOATS**

Coach or individual support boats shall remain no less than 150m from areas where boats are racing, between the Preparatory Signal and the last competitor finishing the race. Failure to comply may result in action from the Protest Committee.

## **14. RADIO COMMUNICATION**

A boat shall neither make radio transmissions while racing nor receive radio communications not available to all boats. This restriction also applies to mobile telephones.

## **15. PRIZES**

Prizes will be given as follows: **Overall Winner** and **Masters Winner**.

## **16. DISCLAIMER OF LIABILITY**

Competitors participate in the regatta entirely at their own risk. See **RRS 4**, Decision to Race. Neither the Organizing Authority nor its officials or other persons associated with the organization of the event will accept any liability for material damage or personal injury or death sustained in conjunction with or prior to, during, or after the regatta.

## **17. INSURANCE**

Each participating boat is encouraged to carry sufficient valid third-party liability insurance to cover any liability arising during the event.

## **18. FURTHER INFORMATION**

For further information please contact:

**Ian MacRobert:** 082 920 0924 [ian.macrobot@za.southernspars.com](mailto:ian.macrobot@za.southernspars.com)

**Markus Progli:** 082 957 2841 [markus@za.northsails.com](mailto:markus@za.northsails.com)

**Stephen du Toit:** 083 658 2659 [zeekoei@jafrika.com](mailto:zeekoei@jafrika.com)

**ADDENDUM #1**

**A Windward-Leeward-Triangle Course**

**Course 1**

**Start - 1 - 2 - 3 - 1 - 3 - 1 - 2 - 3 - Finish**

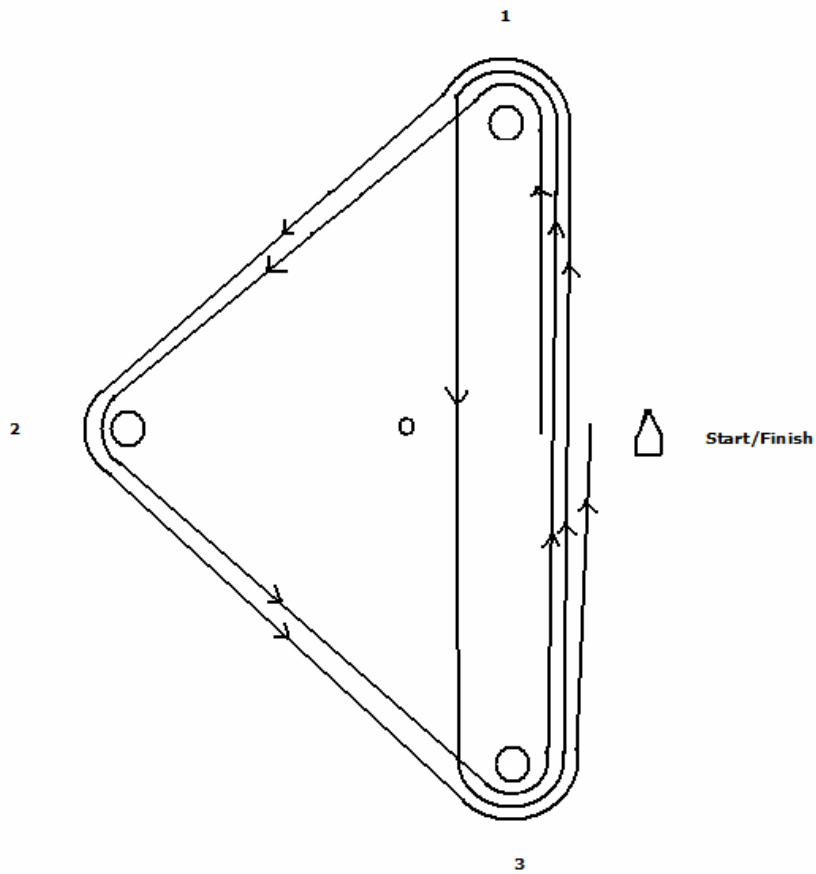

# A Windward-Leeward-Triangle Course

## Course 2

Start - 1 - 2 - 3 - 1 - 3 - Finish

