



Extra Class National Championship 2011

Sanctioned 22 June 2011

SAILING INSTRUCTIONS

1. RULES

- 1.1 The regatta will be governed by the rules as defined in **The Racing Rules of Sailing (RRS) 2009-12.**
- 1.2 The following prescriptions of the South African National Authority apply: **The South African Sailing (SAS) Requirements for National Championships**
- 1.3 **The Equipment Rules of Sailing (ERS) 2009-12 and all Class Rules** will apply.

2. NOTICE TO COMPETITORS

Notices to competitors will be posted on the official notice board(s) located at Port Owen Yacht Club.

3. CHANGES TO SAILING INSTRUCTIONS

Any change to the sailing instructions will be posted before (09h00) on the day it will take effect, except that any change to the schedule of races will be posted by 19h00 on the day before it will take effect.

4. SIGNALS MADE ASHORE

- 4.1 Signals made ashore will be displayed on the flagpole outside the clubhouse.
- 4.2 When flag AP is displayed ashore, "1 minute" is replaced with "not less than 30 minutes" in the race signal AP.

5. SCHEDULE OF RACES

- 5.1 Dates of racing:
14 October 2011 ~ Racing
15 October 2011 ~ Racing
16 October 2011 ~ Racing
- 5.2 Maximum number of races: 16
- 5.3 The scheduled time of the warning signal for the first race on Friday, 14 October 2011, is 13h30. The scheduled time for the warning signal for the first race of each subsequent day will be displayed on the regatta notice board.
- 5.4 On the last day of the regatta no Warning Signal will be made after 17h00.

6. CLASS FLAG

The class flag will be the Extra Class Flag (Black with a Red "X").

7. RACING AREAS

The racing area will be in St. Helena Bay or on the Berg River. Addendum #2 shows the location of racing area.

8. THE COURSE

8.1 The diagrams in Addendum #1 show the general courses, including the approximate angles between legs, the order in which marks are to be passed, and the side on which each mark is to be left.

8.2 The course for the day will be posted on the notice board.

8.3 Competitors to be notified of a change from Course 1 to Course 2 or vice versa, via a notice board on the back of the Committee Boat, not less than five minutes before the start of the race.

9. MARKS

9.1 Marks 1, 2 and 3 will be large yellow buoys.

9.3 The starting and finishing marks will be a small orange mark with a flag.

10. THE START

10.1 Races will be started by using RRS 26 with the Warning Signal given 5 minutes before the starting signal.

10.2 The starting line will be between the mast on the Committee Boat displaying an orange flag and a small mark with a flag on the port side.

10.3 Boats who's Warning Signal has not been made shall avoid the starting area if another class start is in progress.

10.4 A boat starting later than 10 minutes after her starting signal will be scored Did Not Start. This changes RRS A4 and A5.

10.5 If a boat breaks RRS 30.3, the Race Committee at Mark 1 will point flag X at her, make a sound signal and hail her sail number. The hailed boat shall immediately leave the course area. If she fails to do so she will be disqualified without a hearing and her score will not be excluded. This changes RRS A5.

11. CHANGE OF THE NEXT LEG OF THE COURSE

11.1 To change the next leg of the course, the Race Committee will move the original mark (or the finishing line) to a new position.

11.2 Except at a gate, boats shall pass between the Race Committee boat signaling the change of the next leg and the nearby mark, leaving the mark to (port) and the Race Committee boat to starboard. This changes RRS 28.1.

12. THE FINISH

The same line as the Start is to be used as the Finish Line (see 10.2).

13. SHORTENING COURSE

Should the Race Committee shorten course, the finishing line will be at a rounding mark, between the mark and a Boat with a staff displaying the Code Flag "S".

14. TIME LIMITS

Boats failing to finish within 15 minutes after the first boat sails the course and finishes will be scored Did Not Finish. This changes RRS 35, A4 and A5.

15. NATIONAL CHAMPIONSHIP REQUIREMENTS

In order to qualify as a National Class Championship the following criteria shall be satisfied:

- A minimum of ten valid entries have been received no later than the closing time for entries one hour before the scheduled starting time of the first race.
- At least ten finishes in any two races of the series;
- At least four races completed.

16. PROTESTS AND REQUESTS FOR REDRESS

16.1 Protest forms are available from the Race Committee. Protest shall be delivered to the Race Committee within the protest time limit.

16.2 The protest time limit is 60 minutes after the last boat has finished the last race of the day. The same time limit applies to protests by the Race Committee and Protest Committee about incidents they observe in the racing area and to requests for redress. This changes RRS 61.3 and 62.2

16.3 Notices will be posted within 30 minutes after the protest time limit to inform competitors of hearings and times thereof in which they are parties or named as witnesses. Hearings will be held in the jury room, located at Port Owen Yacht Club.

16.4 Notices of protest by the Race Committee or Protest Committee will be posted to inform boats under RRS 61.1(b).

16.5 On the last day of the regatta a request for reopening a hearing shall be delivered.

(a) within the protest time limit if the requesting party was informed of the decision on the previous day;

(b) no later than 30 minutes after the requesting party was informed of the decision that day.

This changes RRS 66.

16.6 On the last day of the regatta a request for redress from a Protest Committee decision shall be delivered no later than 30 minutes after the decision was posted. This changes RRS 62.2.

17. SCORING

17.1 The Low Point scoring system of Appendix A will apply.

17.2 Four races are required to be completed to constitute a series.

- When fewer than 5 races have been completed, a boats series score will be the total of her race scores.
- When from 5 to 9 races have been completed, a boats series score will be the total of her race scores excluding her worst score.
- When 10 or more races have been completed, a boats series score will be the total of her race scores excluding her two worst scores.

18. SAFETY REGULATIONS

18.1 A boat that retires from a race shall notify the Race Committee as soon as possible.

18.2 Yachts shall comply with their class buoyancy and safety requirements.

18.3 All competitors shall wear a personal buoyancy aid capable of supporting a 5kg steel weight at all times while afloat in a yacht.

18.4 Wet or Dry suits do not constitute adequate buoyancy!

19. REPLACEMENT OF CREW OR EQUIPMENT

19.1 Substitution of competitors will not be allowed without prior approval of the Race Committee.

19.2 Substitution of damaged or lost equipment will not be allowed unless approved by the Race Committee.

20. EQUIPMENT AND MEASUREMENT CHECKS

A boat or equipment may be inspected at any time for compliance with the Class Rules and Sailing Instructions. On the water, a boat can be instructed by a Race Committee Measurer to proceed immediately after the completion of a race to a designated area for inspection.

21. SUPPORT BOATS

Team leaders, coaches and other support personnel shall stay 50 meters outside areas where boats are racing from the time of the Preparatory Signal for the first class to start until all boats have finished or the Race Committee signals a postponement, general recall or abandonment. Non-compliance with this rule may lead to action under RRS 69.

22. TRASH DISPOSAL

Boats shall not discard trash in the water. Trash may be placed aboard support and Race Committee boats.

23. RADIO COMMUNICATION

A boat shall neither make radio transmissions while racing nor receive radio communications not available to all boats. This restriction also applies to mobile telephones.

24. PRIZES

Prizes will be awarded as detailed in the Notice of Race.

25. DISCLAIMER OF LIABILITY

Competitors participate in the regatta entirely at their own risk; see RRS 4, Decision to Race. The Organising Authority, nor any of its personnel, will not accept any liability for material damage or personal injury or death sustained in conjunction with or prior to, during, or after the regatta.

26. INSURANCE

Each participating boat is encouraged to carry sufficient valid third-party liability insurance to cover any liability arising during the event.

SEE COURSE ADDENDUMS BELOW!!

ADDENDUM #1

A Windward-Leeward-Triangle Course

Course 1

Start - 1 - 2 - 3 - 1 - 3 - 1 - 2 - 3 - Finish

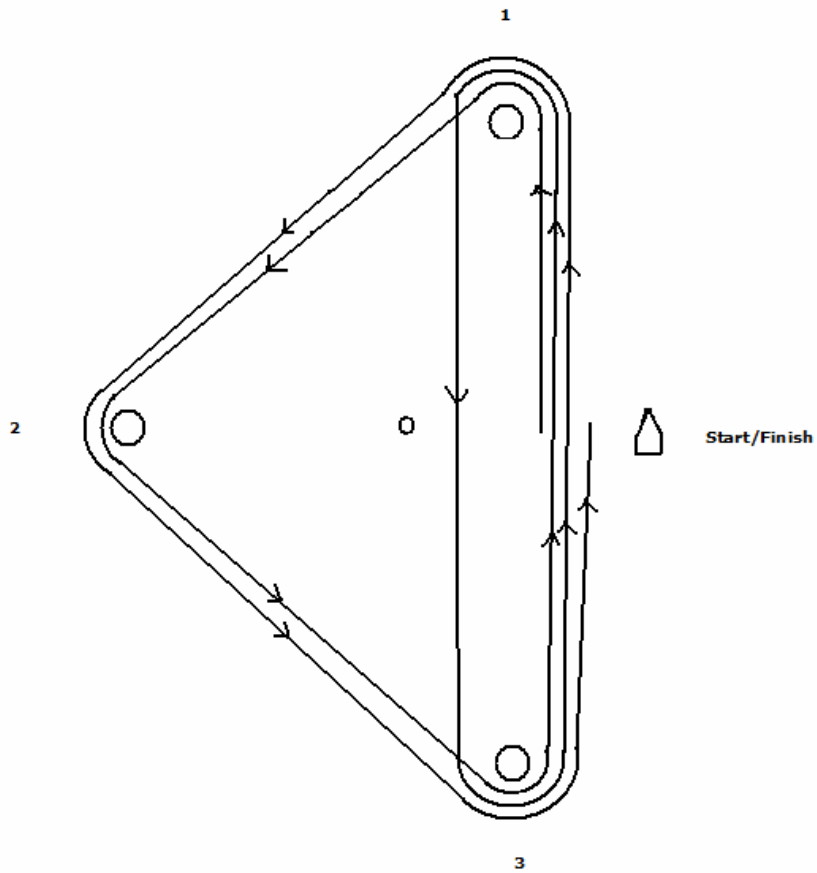

A Windward-Leeward-Triangle Course

Course 2

Start - 1 - 2 - 3 - 1 - 3 - Finish

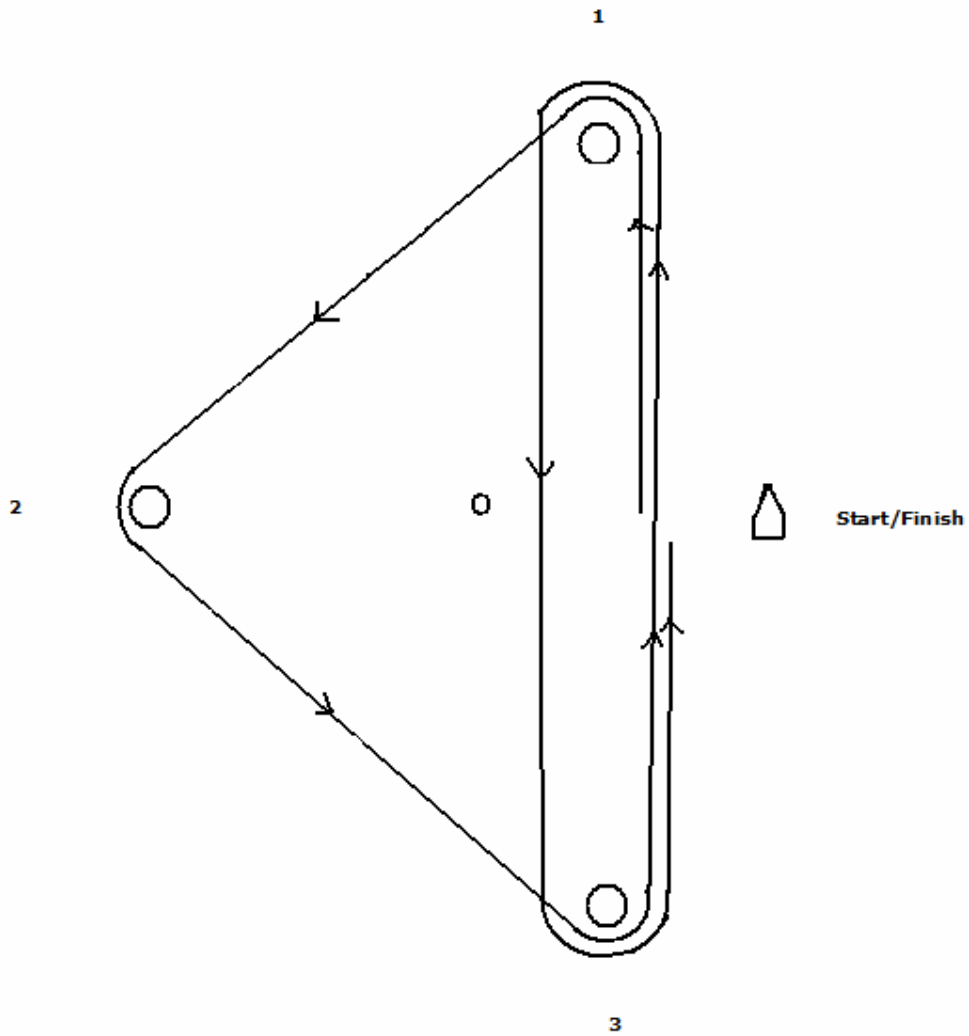

ADDENDUM #2

